

TPG®

MOTORS & DRIVES

www.tpg-tw.com

- 信賴性ある製品 TECHNOLOGY
- 卓越したの性能 PERFECTION
- 保証したの品質 GUARANTEE

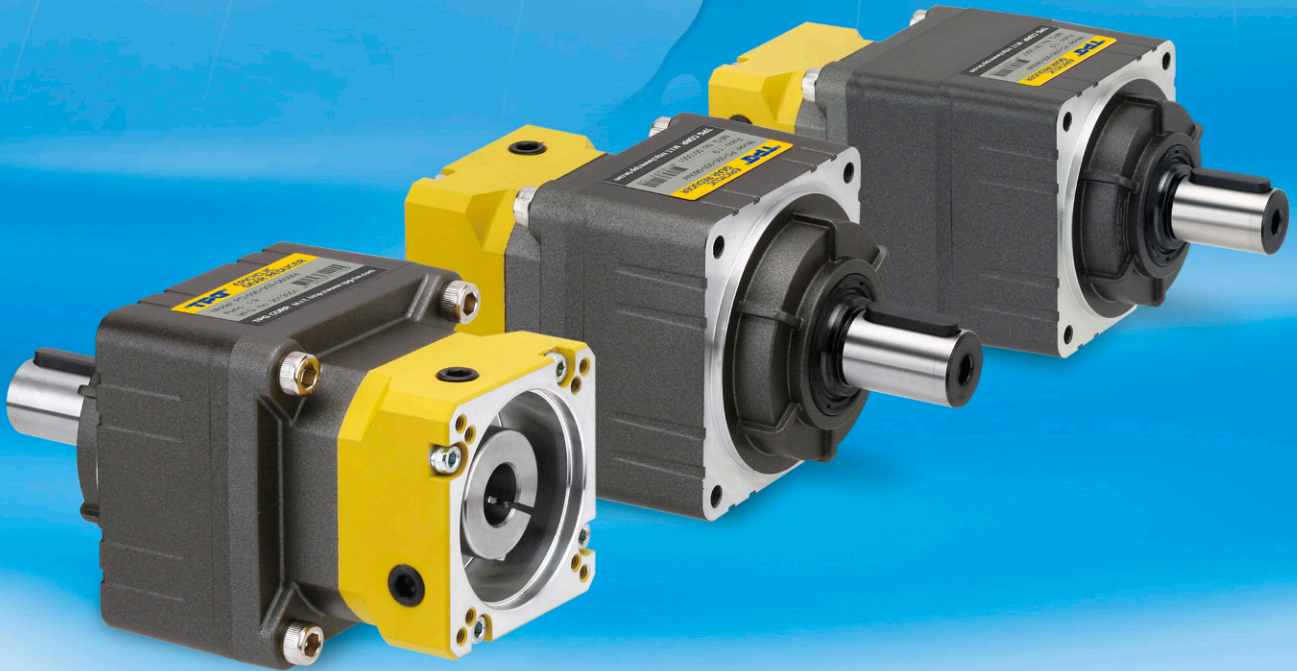

PA 減速機系列
精密行星式減速機

PLANETARY SERVO REDUCERS

阪神電機
TPG MOTORS & DRIVES

TPG made planetary gear box contains one or two planet sets, which is great selection for servo motor, automation motor... etc.

PA type is parallel axis gear box, ratio from 3 to 81, 1 & 2 stage available.

TPG 阪神電機持續進步開創各式減速機，以滿足不同產業之期望，推出行星式齒輪減速機，可依產業需求連結各式伺服馬達，主軸馬達等。

PA系列為平行軸齒輪減速機，比數從3-81，提供一段式或二段式齒輪箱結構。

Advantages:

- Offer more accuracies than traditional gear box
- Supply high power density, durable and long lifetime
- Larger reduction in small space.
- 3% mechanical loss only, save energy and create more efficiency
- Average load distribution increase more rotational stiffness
- Multiple assortment combinations can be added in
- Special bearing installed in the end of output shaft to reduce the vibration occurred while motor running
- Alum. Die cast house offer impact size and nice shape design.
- Flexible flange or frame can be jointed with different brand servo motors.
- High quality Chrome alloy material gear with special heat treatment to enforce the torque ability.
- Wide range gear ratio applies to more different operations in the same gear box body.

特性:

1. 提供更精細的齒輪準確性。
2. 壓鑄鋁合金機體，密度堅實且美觀大方，耐用長壽。
3. 在有限的空間裡可提供與一般傳統減速機相當的比數。
4. 負載可被平均分攤，因而增加齒輪的剛度。
5. 提供複合多功能的選配。
6. 出力軸安裝軸承，有效減小馬達運轉時所產生的振動。
7. 可選用多款連接法蘭，以搭配不同廠家的伺服馬達。
8. 高品質合金鋼齒輪材質經熱處理加工後，扭力值更為加強。
9. 一段、二段齒輪箱的組合，加大減速比範圍。

PA Series

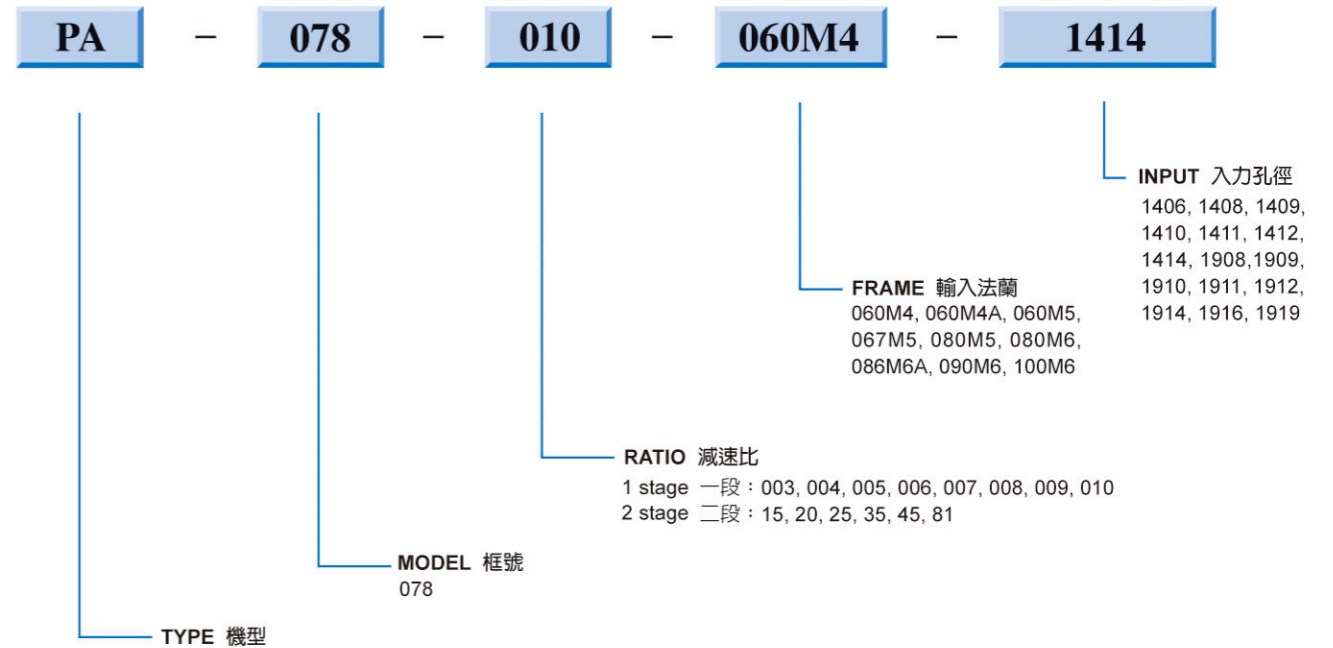

適用馬達馬力 Available Power Visit Ratio

Motor Rated Output (W)	減速比 Ratio													
	3	4	5	6	7	8	9	10	15	20	25	35	45	81
50													●	●
100												●	●	●
200									●	●	●	●		
400				●	●	●	●	●	●	●				
500	●	●	●	●	●	●	●	●	●					
600	●	●	●											
750	●	●	●											

輸出額定轉速 Concentric Shaft Series Specification

Maximum Input Speed 6000 RPM 最大輸入轉速	減速比 Ratio													
	3	4	5	6	7	8	9	10	15	20	25	35	45	81
Nominal Output Torque (Nm) 額定轉矩	21	21	21	21	21	21	21	21	26	26	26	26	26	26



輸入法蘭尺寸表 Input Frame Dimension of PA-078

尺寸表 Dimension

mm

Frame Type	LC	LH	LD	LJ	L	LK	LF	LG	ML
060M4	60	50	60	M4xP0.7	140.5	11	4	5	42
	70	50	60	M4xP0.7	140.5	11	4	5	42
060M4A	63	40	60	M4xP0.7	140.5	11	4	5	42
060M5	70	50	60	M5xP0.8	140.5	11	4	5	42
060M5A	70	50	60	M5xP0.8	144.5	15	6	9	46
067M5	75	60	67	M5xP0.8	140.5	11	4	5	42
080M5	90	70	80	M5xP0.8	140.5	11	4	5	42
080M6	90	70	80	M6xP1.0	145.5	16	9	10	47
080M6A	90	70	80	M6xP1.0	140.5	11	4	5	42
086M6	95	80	86	M6xP1.0	140.5	11	4	5	42
086M6A	100	80	86	M6xP1.0	140.5	11	4	5	42
090M6	104	83	90	M6xP1.0	140.5	11	4	5	42
100M6	115	95	100	M6xP1.0	140.5	11	4	5	42
100M8	115	95	100	M8xP1.25	140.5	11	4	5	42

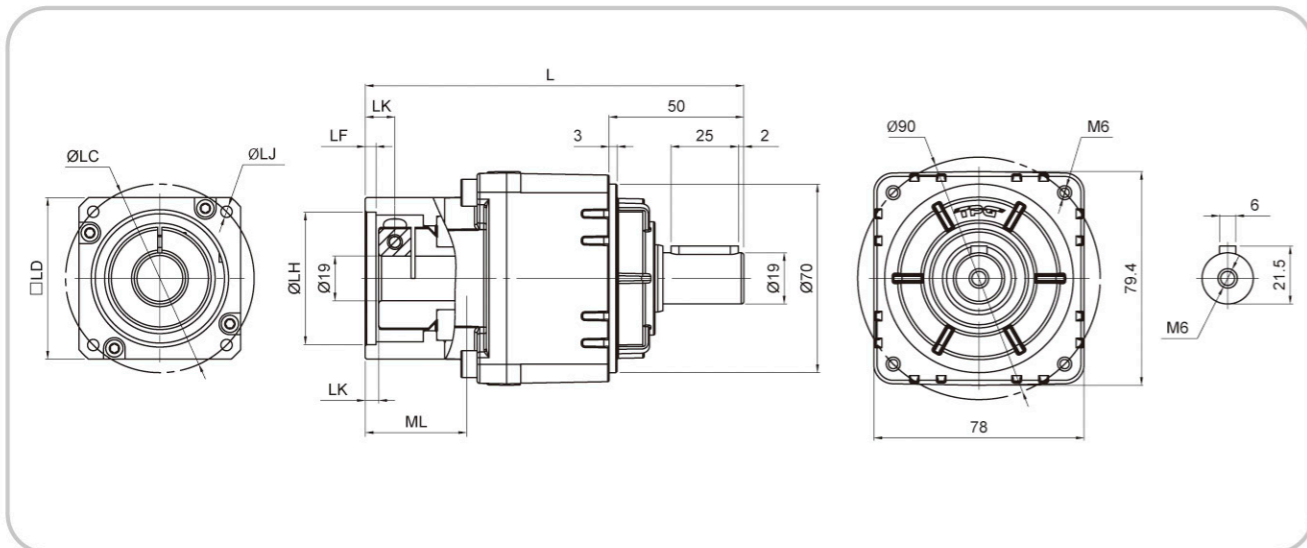

(1) 出廠標準入力孔徑為14，若需其它規格孔徑請另行註明，需加裝軸套。(1) Factory standard input dia. is 14mm, others must be added bush.
 (2) 特殊規格要求請告知。(2) Tailor spec. request available.



PA-078 TYPE 1 - STAGE
Ratio: 3, 4, 5, 6, 7, 8, 9, 10

零件組 Explosion Drawing

No.	品名	No.	品名	No.	品名
1	齒輪箱 Gear house	9	油封 Oil seal	17	止附螺絲 Screw
2	齒輪箱蓋 Gear box cover	10	油封 Oil seal	18	套筒螺絲 Socket screw
3	一段軸 1st stage shaft	11	軸承 Bearing	19	直梢 Pin
4	游星齒 Planet gear	12	軸承 Bearing	20	滾針軸承 Needle bearing
5	內齒輪 Internal gear	13	軸承 Bearing	21	套筒螺絲 Socket screw
6	出力軸 Output shaft	14	軸承 Bearing	22	套筒螺絲 Socket screw
7	入力軸 Input shaft	15	扣環 O ring	23	雙圓鍵 Key
8	輸入法蘭 Input flange	16	止附螺絲 Screw		

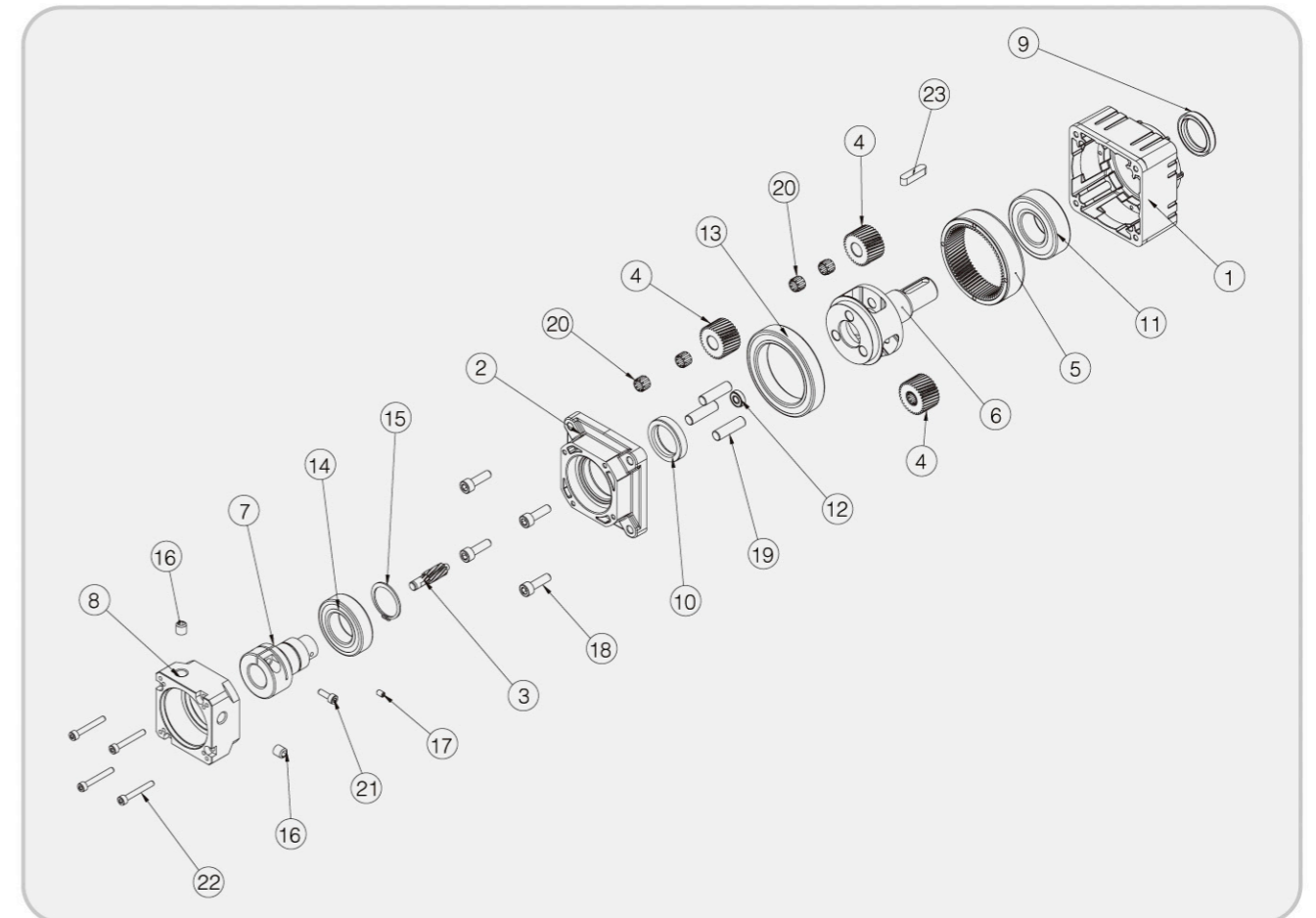

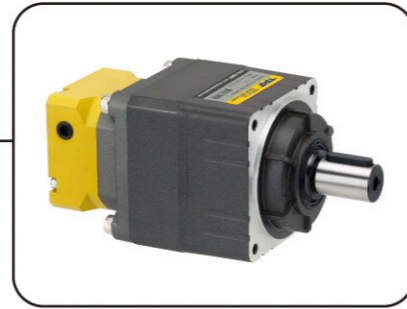

輸入法蘭尺寸表 Input Frame Dimension of PA-078

尺寸表 Dimension

mm

Frame Type	LC	LH	LD	LJ	L	LK	LF	LG	ML
060M4	60	50	60	M4xP0.7	168.5	11	4	5	42
	70	50	60	M4xP0.7	168.5	11	4	5	42
060M4A	63	40	60	M4xP0.7	168.5	11	4	5	42
060M5	70	50	60	M5xP0.8	168.5	11	4	5	42
060M5A	70	50	60	M5xP0.8	172.5	15	6	9	46
067M5	75	60	67	M5xP0.8	168.5	11	4	5	42
080M5	90	70	80	M5xP0.8	168.5	11	4	5	42
080M6	90	70	80	M6xP1.0	173.5	16	9	10	47
080M6A	90	70	80	M6xP1.0	168.5	11	4	5	42
086M6	95	80	86	M6xP1.0	168.5	11	4	5	42
086M6A	100	80	86	M6xP1.0	168.5	11	4	5	42
090M6	104	83	90	M6xP1.0	168.5	11	4	5	42
100M6	115	95	100	M6xP1.0	168.5	11	4	5	42
100M8	115	95	100	M8xP1.25	168.5	11	4	5	42

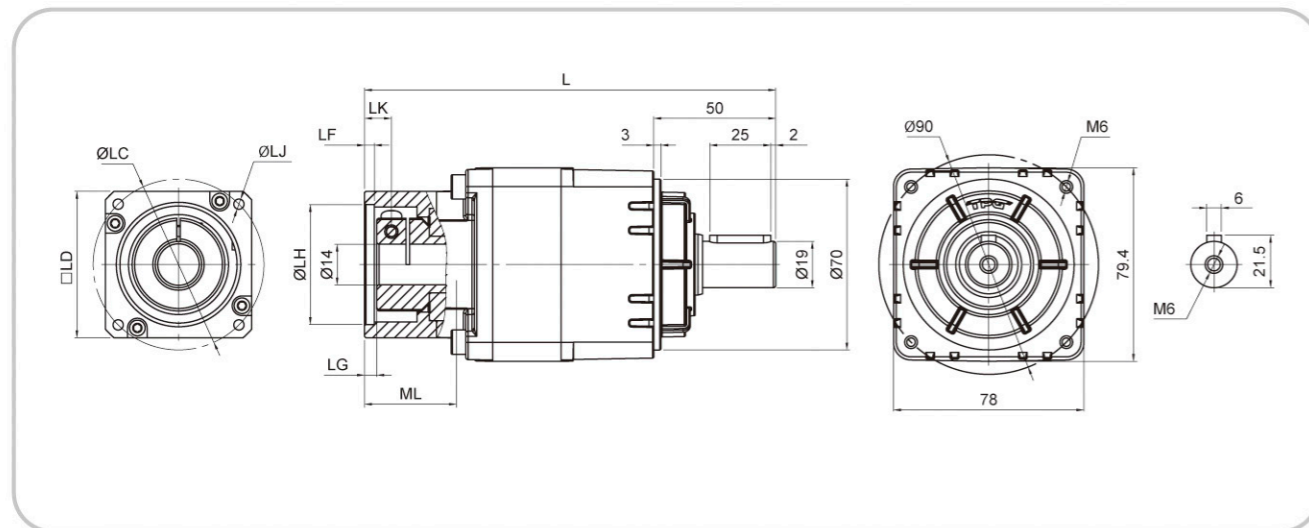

(1) 出廠標準輸入孔徑為14，若需其它規格孔徑請另行註明，需加裝軸套。
 (2) 特殊規格要求請告知。

(1) Factory standard input dia. is 14mm, others must be added bush.
 (2) Tailor spec. request available.



PA-078 TYPE 2 - STAGE
Ratio: 15, 20, 25, 35, 45, 81

零件組 Explosion Drawing

No.	品名	No.	品名	No.	品名
1	齒輪箱 Gear house	11	軸承 Bearing	21	套筒螺絲 Socket screw
2	齒輪箱蓋 Gear box cover	12	軸承 Bearing	22	套筒螺絲 Socket screw
3	一段軸 1st stage shaft	13	軸承 Bearing	23	雙圓鍵 Key
4	游星齒 Planet gear	14	軸承 Bearing	24	中段齒輪箱 2nd gear house
5	內齒輪 Internal gear	15	扣環 O ring	25	內齒輪 Internal gear
6	出力軸 Output shaft	16	止附螺絲 Screw	26	二段連接軸 2nd connection shaft
7	入力軸 Input shaft	17	止附螺絲 Screw	27	一段軸 1st stage shaft
8	輸入法蘭 Input flange	18	套筒螺絲 Socket screw	28	游星齒 Planet gear
9	油封 Oil seal	19	直梢 Pin	29	直梢 Pin
10	油封 Oil seal	20	滾針軸承 Needle bearing		

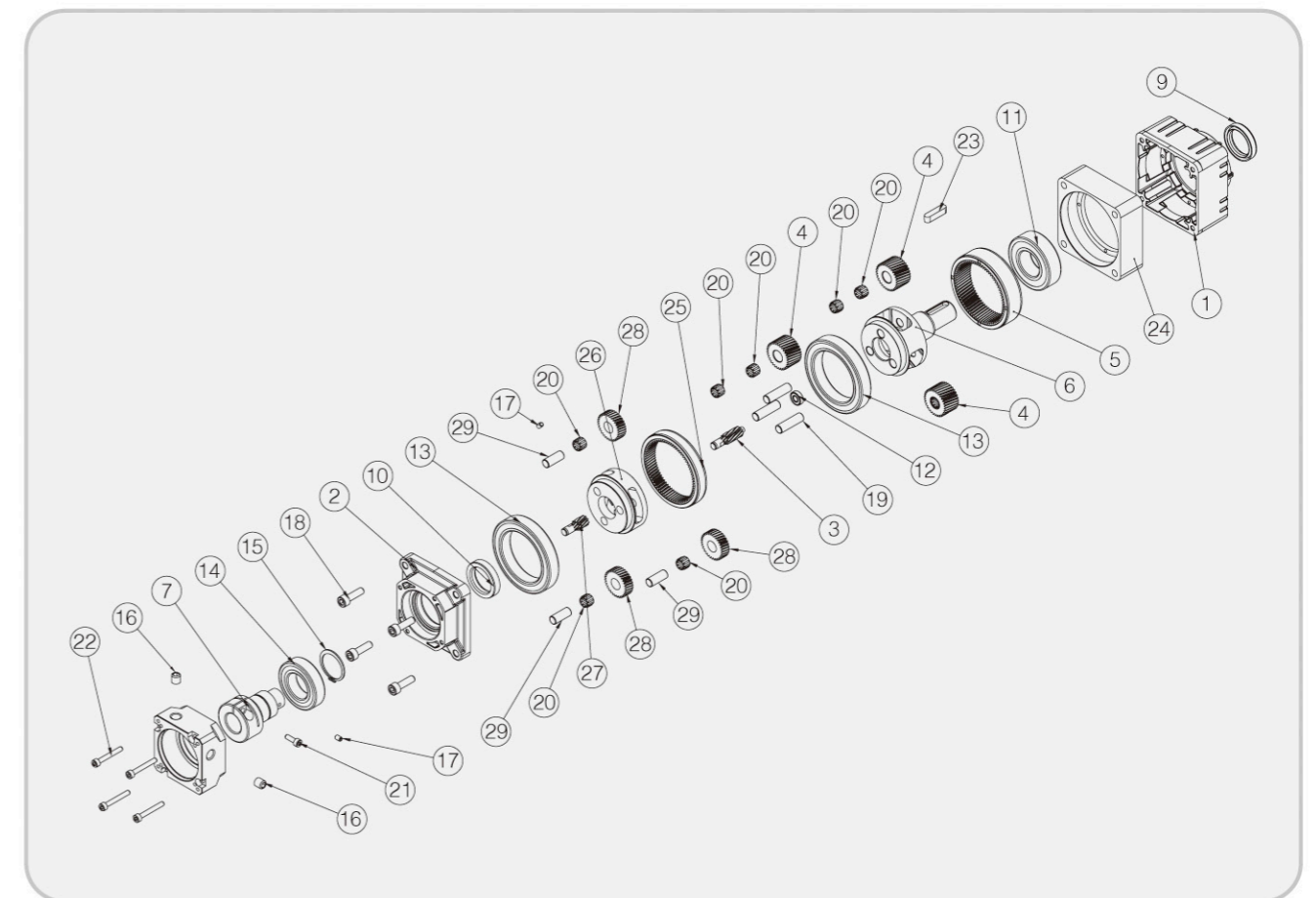

規格如有變更，恕不另行通知。The specifications are subject to change by the manufacturer without prior notice.

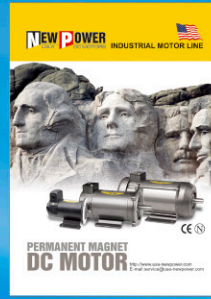
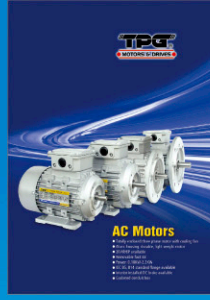
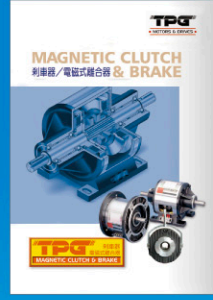
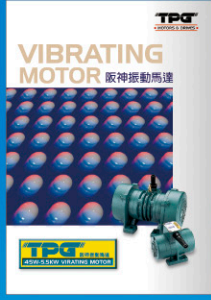
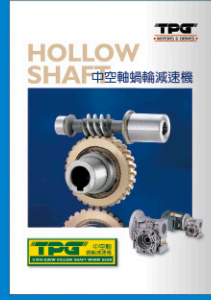

ISO 9001 : 2008

HEAD OFFICE:
TAIWAN PRECISION GEAR CORP
 TEL: 886-4-25351329 FAX: 886-4-25351467
 E-mail: tpgcorp@ms13.hinet.net

BRANCH:
(CHINA)
TPG MOTORS & DRIVES (CHINA) CO., LTD.
 TEL: 86-769-22335207 FAX: 86-769-22335203
 E-mail: tpgcorp@163.com

(THAILAND)
TPG MOTORS & DRIVES (THAILAND) CO., LTD.
 TEL: 66-2-2778878 FAX: 66-2-2779788
 E-mail: tpg_th@yahoo.com

(VIETNAM)
TPG MOTORS & DRIVES (VIETNAM) CO., LTD.
 TEL: 84-8-3-8165878 FAX: 84-8-3-8165876
 E-mail: tpg_vn@yahoo.com

(INDIA)
TPG MOTORS & DRIVES (INDIA) PVT. LTD.
 TEL: 91-44-23634199 FAX: 91-44-23634299
 E-mail: tpg_in@yahoo.com

(MALAYSIA)
TPG MOTORS & DRIVES (MALAYSIA) SDN BHD
 TEL: 60-3-89616916 FAX: 60-3-89641980
 E-mail: tpg_ma@yahoo.com

(INDONESIA)
TPG MOTORS & DRIVES (INDONESIA) CO., LTD.
 TEL: 62-21-45846725 FAX: 62-21-45846726
 E-mail: tpg_ind@yahoo.com

(SINGAPORE)
TPG MOTORS & DRIVES (SINGAPORE) PTE LTD.
 TEL: 65-62456007 FAX: 65-62456017
 E-mail: tpgsin@singnet.com.sg